

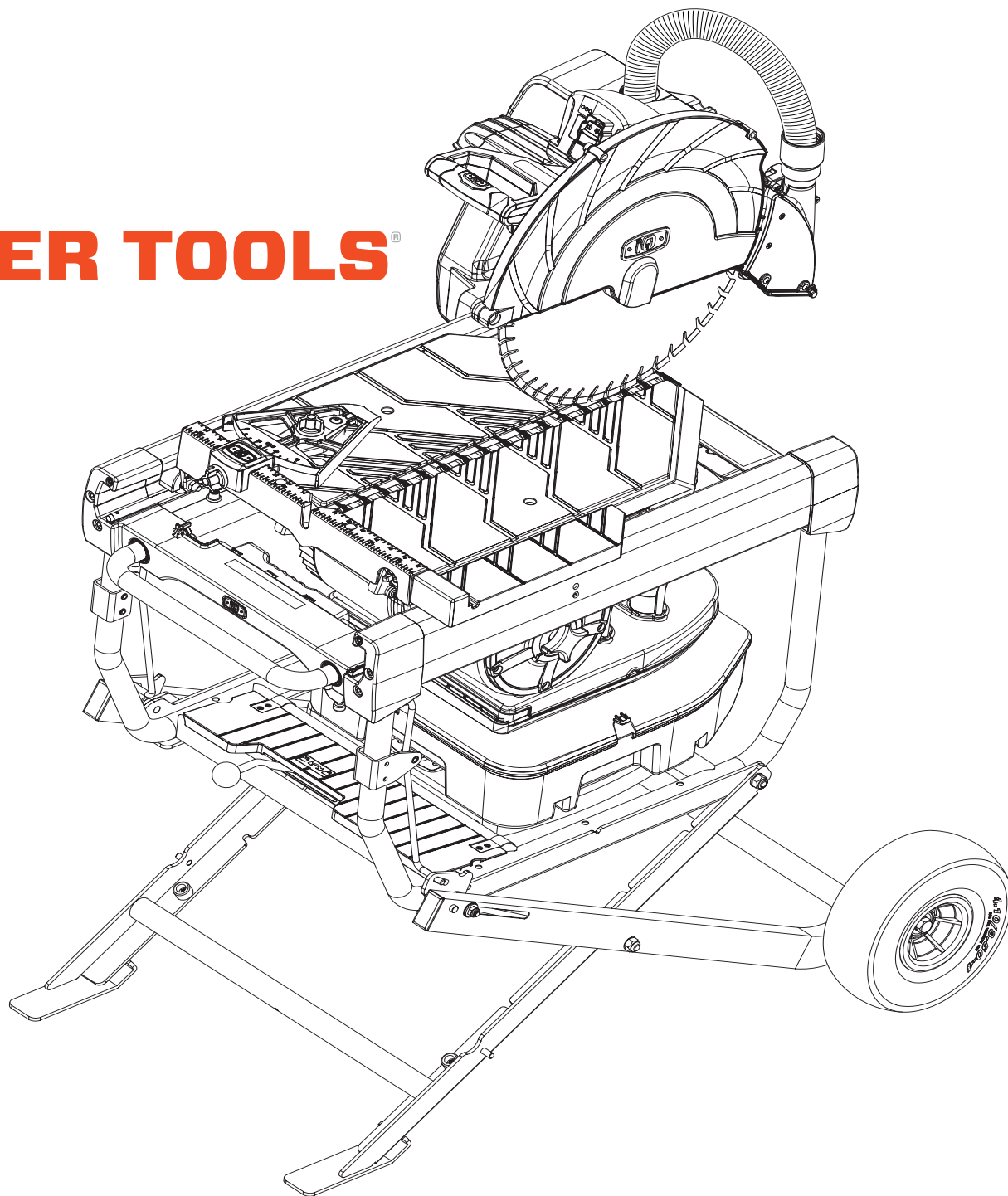

POWER TOOLS®



iQMS362i US

Parts Manual

M-iQMS362-001-PM052020

FRONT ANGLED VIEW

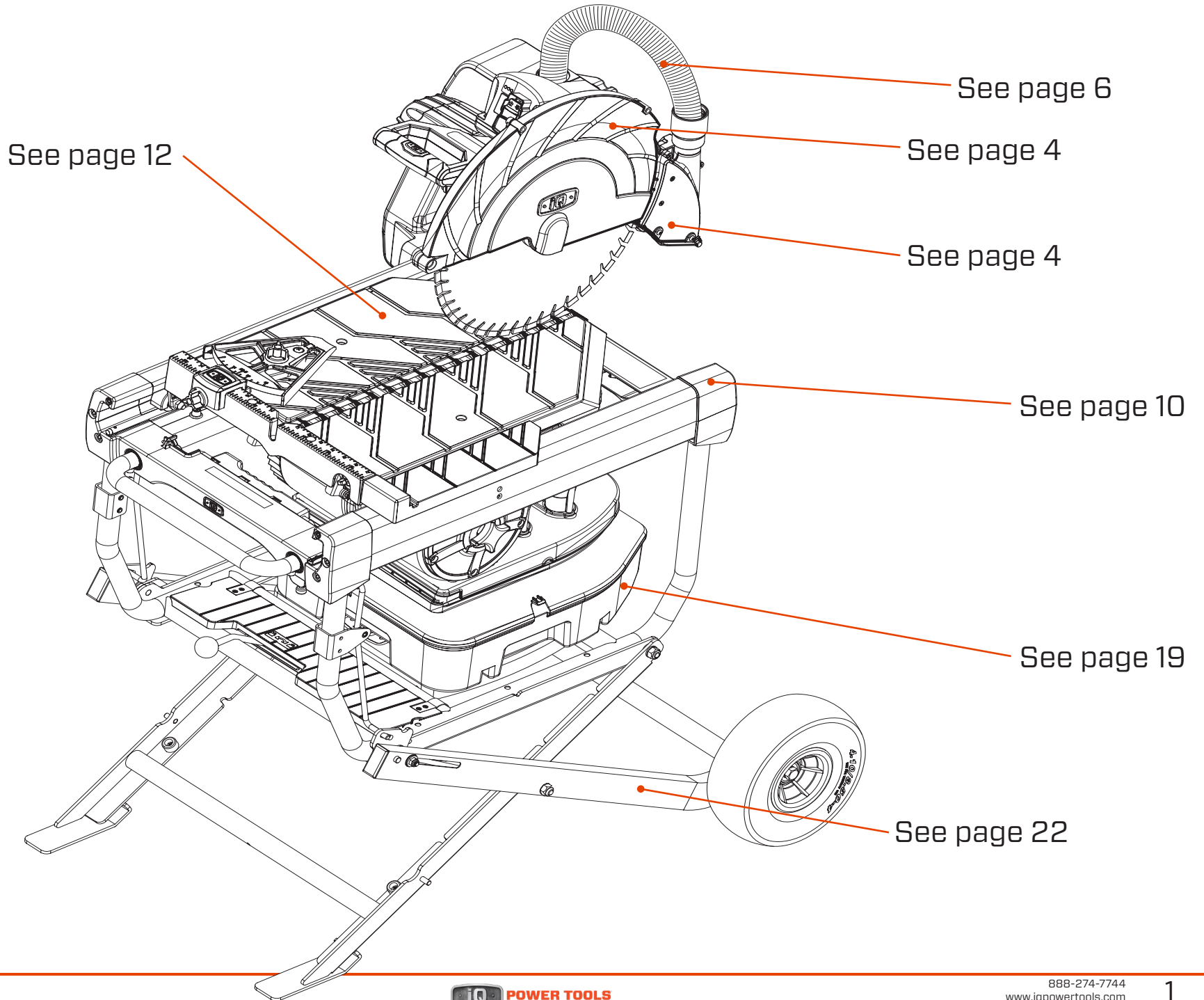

BACK ANGLED VIEW

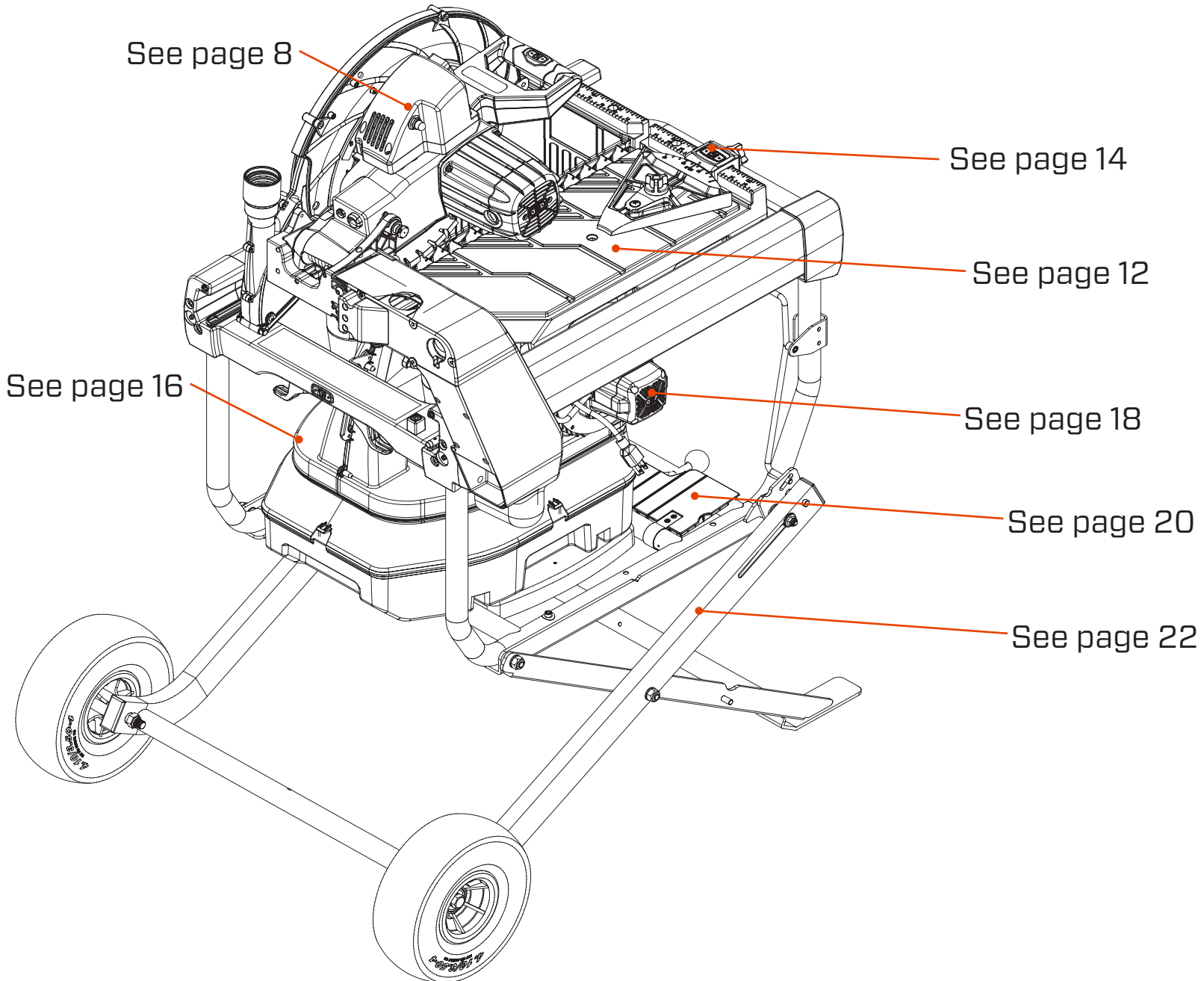

VACUUM SYSTEM VIEW

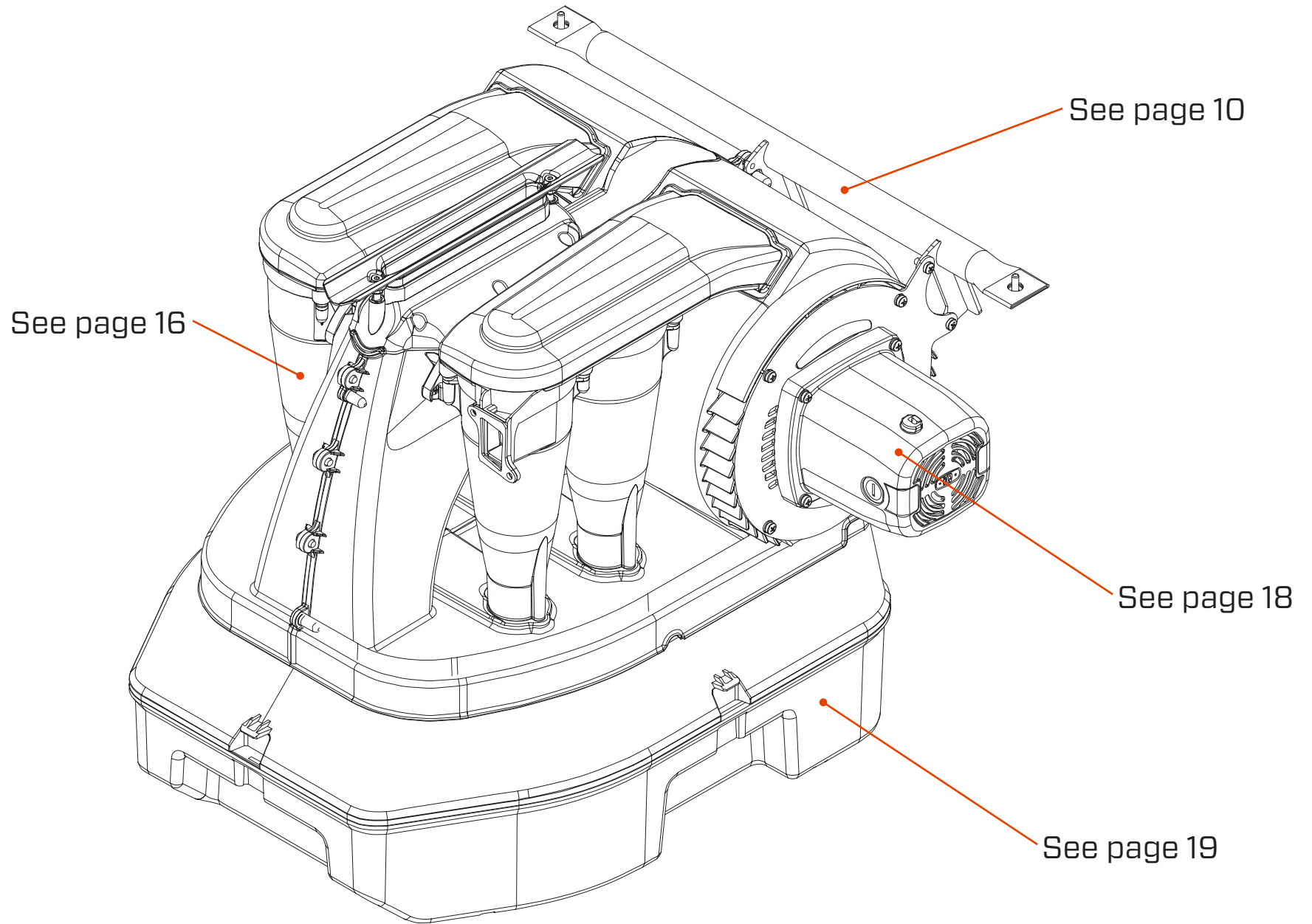

BLADE GUARD & DUST GUARD

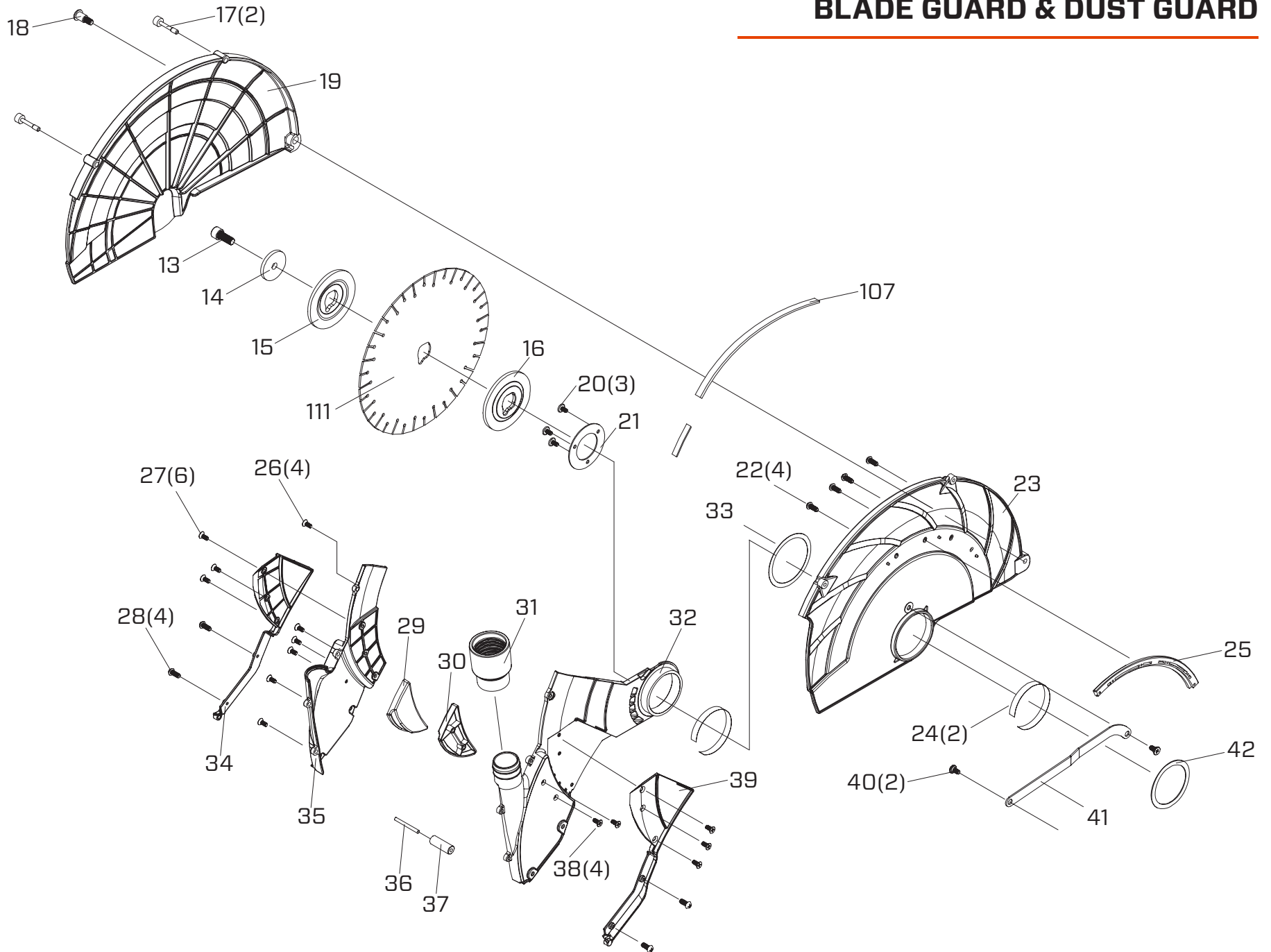

BLADE GUARD & DUST GUARD

ASSEMBLY KIT / SET	ITEM NO	QTY	PART NO	DESCRIPTION
	13	1	0360-62087-01	Hex Screw with Washer
	14	1	0360-62088-01	Outer Flange Washer
	15	1	0362-00015-01	Flange, Outside
	16	1	0362-00016-01	Flange, Inside
SET	17	1	0362-90069-01	Screw (Set of 2)
	18	1	0362-00018-01	Shoulder Screw
	19	1	0362-00019-01	Blade Guard, Outside
SET	20	1	0362-90070-01	Screw (Set of 3)
	21	1	0362-00021-01	Retaining Plate
SET	22	1	0362-90071-01	Screw (Set of 4)
SET	24	1	0362-90072-01	Wear Washer (Set of 2)
	25	1	0362-00025-01	Guide Rail
SET	26	1	0362-90074-01	Screw (Set of 4)
K1	K1	1	0362-90001-01	Dust Guard Hardware Kit
	27	6		Screw
	28	4		Screw
	34	1		Dust Guide Plate, Outer
	39	1		Dust Guide Plate, Inner

ASSEMBLY KIT / SET	ITEM NO	QTY	PART NO	DESCRIPTION
K2	K2	1	0362-90002-01	Dust Guard Inserts
	29	1		Plastic Insert, R
	30	1		Plastic Insert, L
	38	4		Screw
	31	2	0362-00031-01	Hose End
	32	1	0362-00032-01	Dust Guard, Inner
	33	1	0362-00033-01	Washer
	35	1	0362-00035-01	Dust Guard, Outer
K3	K3	1	0362-90003-01	Guide Roller Kit
	36	1		Guide Wheel Pin
	37	1		Guide Wheel
SET	40	1	0362-90075-01	Link Arm Screw (Set of 2)
	41	1	0362-00041-01	Guard Link Arm
	42	1	0362-00042-01	Washer
	111	1	MASQX16-125-QD-KP	16" Q-Drive Combo Blade Silent Core
K71	K71	1	0362-90054-01	Blade Guard, Inside Kit
	23	1		Blade Guard, Inside
	107	1		Gasket

SUPPORT ARM

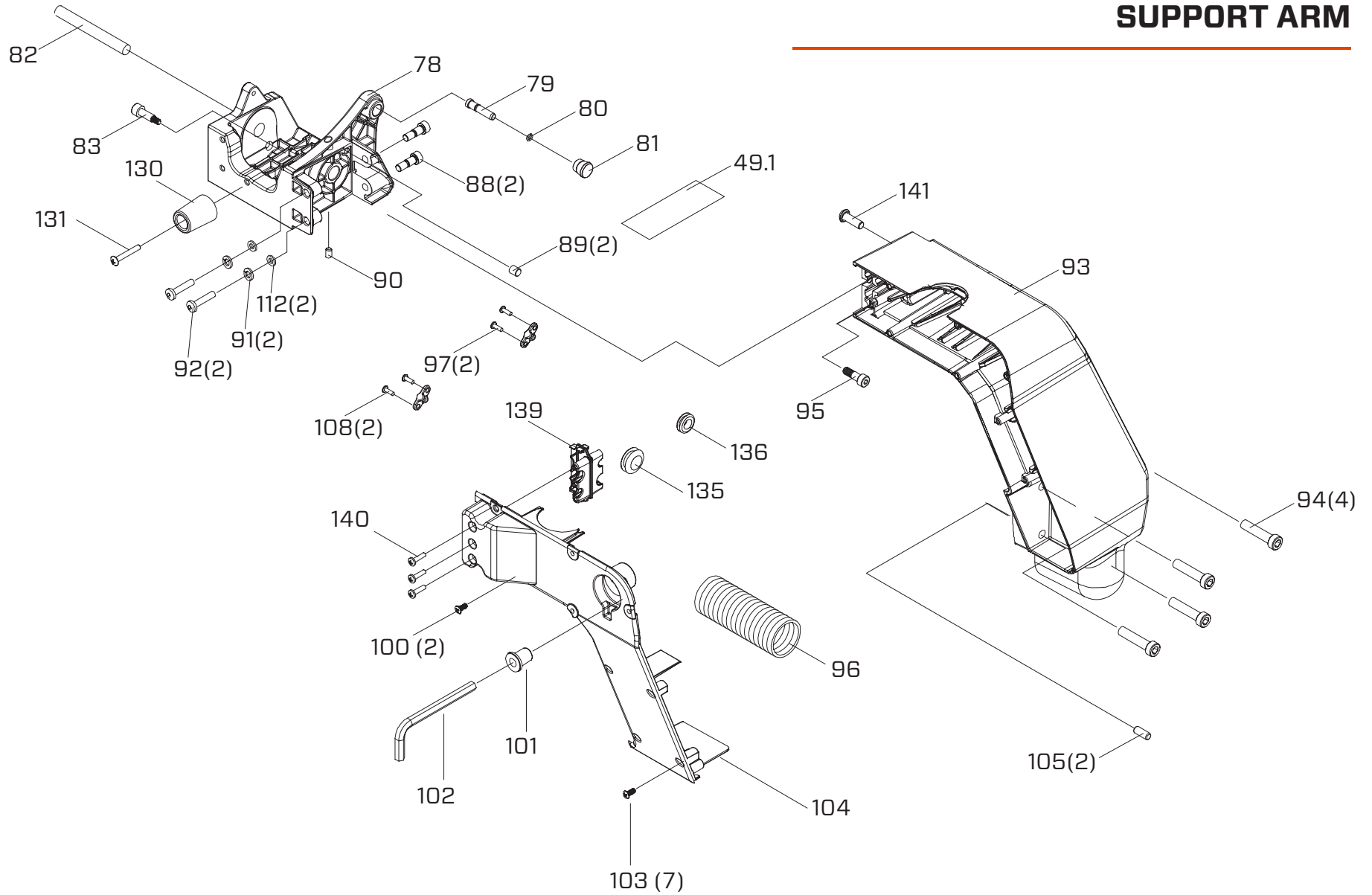

SUPPORT ARM

ASSEMBLY KIT / SET	ITEM NO	QTY	PART NO	DESCRIPTION
K6	K6	1	0362-90005-01	Lock Pin Kit
	79	1		Lock Pin
	80	1		O-ring
	81	1		Lock Pin Knob
	82	1	0362-00082-01	Pivot Shaft
	83	1	0362-00083-01	Screw
SET	88	1	0244-90101-01	Blade Adjustment Screw (Set of 2)
K54	K54	1	0362-90052-02	Motor Pivot Mount Kit
	78	1		Motor Pivot Mount
	89	2	0244-00093-01	Pin
	90	1	0362-00090-01	Set Screw
K8	K8	1	0362-90007-01	Hardware Kit
	91	2		Lock Washer
	92	2		Hex screw
	112	2		Washer
K69	K69	1	0362-90053-02	iQMS362 Support Arm Kit
	93	1		Support Arm
	141	1		Vertical Adjustment Screw
	89	2		Pin
	105	2		Dowel Pin
K80	K80	1	0362-90104-01	iQMS362 Back Cover Kit
	101	1		Sleeve
	104	1		Support Arm Back Cover
	135/136	1		Cable Clamp Set (135+136)
	139	1		Support Arm Cable Cover
	140	3		Screw (Set of 3)

ASSEMBLY KIT / SET	ITEM NO	QTY	PART NO	DESCRIPTION
SET	94	1	0244-90079-01	Hex Screw w/ Washer (Set of 4)
	95	1	0244-00171-01	Blade Adjustment Screw
	96	1	0362-00096-01	Vacuum Hose
SET	97	1	0362-90076-01	Screw (Set of 2)
K9	K9	1	0362-90009-01	Screw Kit
	100	2		Screw
	103	7		Screw
	101	1	0360-62145-01	Sleeve
	102	1	0362-00102-01	Wrench
	104	1	0362-00104-02	Support Arm Back Cover
	139	1	0362-00139-01	Support Arm Cable Cover
SET	135	1	0426-90053-02	Cable Clamp Set (135+136)
SET	105	1	0244-90080-01	Dowel Pin (Set of 2)
SET	108	1	0244-90065-01	Screw (Set of 2)
K7	K7	1	0362-90006-02	Foot Kit
	130	1		Foot Pad
	131	1		Shoulder Screw
SET	140	1	0362-90103-01	Screw (Set of 3)
K81	K81	1	0362-90105-01	iQMS362i Support Arm Replacement/Upgrade Kit
	K69	1		iQMS362 Support Arm Kit
	104	1		Support Arm Back Cover
	135/136	1		Cable Clamp Set
	139	1		Support Arm Cable Cover
	K9	1		Screw Kit
	140	1		Screw (Set of 3)

GEAR HOUSING & SAW MOTOR

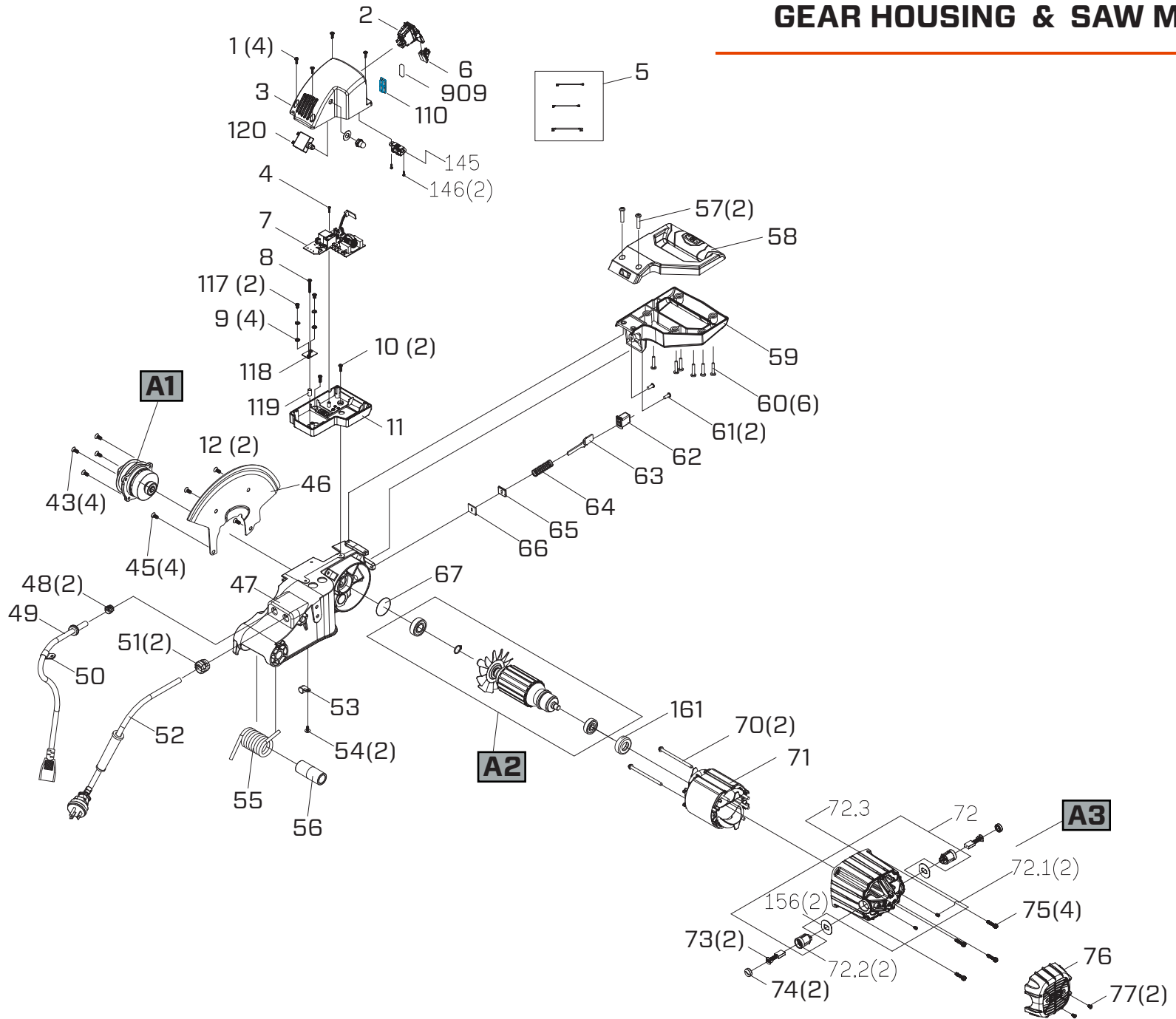

GEAR HOUSING & SAW MOTOR

ASSEMBLY KIT / SET	ITEM NO	QTY	PART NO	DESCRIPTION
K10	K10	1	0362-90010-01	Hardware Kit
	1	4		Screw
	4	1		Screw
	8	1		Screw
	9	1		Washer
	10	3		Screw
K11	K11	1	0362-90011-03	Circuit Board Housing Kit (V3)
	3	1		Circuit Board Housing Top (V3)
	120/5	1		Overload Protector and wire
	6	1		Paddle Lock Ring
	11	1		Circuit Board Housing Bottom (V3)
	110	1		Switch Cover
K12	K12	1	0362-90012-04	Jump Wire A, B, C (Start with S/N 200001)
	5	1		Jump Wire A, B, C
	109	1		Jump Wire E (Removed after S/N 190001)
	120	1	0362-00120-01	Overload Protector
K74	K74	1	0362-90095-01	MS362 120V Overload Protector Kit
	120	1		Overload Protector
	5	1		Jump Wire C Black
	2	1	0362-00002-01	Main Switch
	7 145	1	0360-62079-03 / 0362-90110-01	iQMS362i PCB Module 120v / PCB Module w/LED 120v
	11	1	0244-00054-03	Circuit Board Housing Bottom (V3)
SET	12	1	0244-90087-01	Grommet (Set of 2)
SET	43	1	0362-90077-01	Screw (Set of 4)
A1	A1	1	0362-25001-03	MS362i Blade Shaft Assembly
SET	45	1	0362-90077-01	Screw (Set of 4)
	46	1	0362-00046-02	MS362i Guard Guide Rail
	47	1	0360-62109-02	MS362i Gear Housing
SET	48	1	0362-90078-01	Cord Grip (Set of 2)
	49	1	0362-00049-03	Vacuum Power Cord

ASSEMBLY KIT / SET	ITEM NO	QTY	PART NO	DESCRIPTION
K4	K4	1	0362-90004-02	Cord Strap Kit
	50	1		Cord Clamp
	53	1		Cord Clamp
	54	3		Screw
SET	51	1	0362-90079-01	Cord Grip (Set of 2)
	52	1	0362-00052-01	Power Cord
	55	1	0362-00055-01	Torsion Spring
	56	1	0360-62152-01	Torsion Spring Sleeve
K13	K13	1	0362-90013-01	Handle Hardware Kit
	57	2		Screw
	60	6		Self Tapping Screw
	61	2		Screw
K55	K55	1	0360-90001-01	Saw Motor Main Handle
	58	1		Top Handle
	59	1		Bottom Handle
K15	K15	1	0362-90015-02	Spindle Lock Hardware Kit
	62	1		Spindle Lock Button
	63	1		Spindle Lock
	64	1		Compress Spring
	65	1		Seal Pad
	66	1		Felt Seal
K16	K16	1	0362-90016-02	O-Ring, Bushing
	67	1		O-Ring
	69	1		Bushing
A2	A2	1	0360-62139-02	Armature Assembly
	161	1	0362-00161-01	Bearing Bushing
SET	70	1	0360-90019-01	Screw (Set of 2)
	71	1	0362-62071-01	Stator 120v
A3	A3	1	0362-90098-02	MS362i Saw Motor Housing Assembly
SET	73	1	0360-90014-01	Brush (Set of 2)
SET	74	1	0360-90015-01	Brush Cover (Set of 2)
SET	75	1	0244-90085-02	Screw (Set of 4)
	76	1	0362-00076-01	iQMS362i Motor Housing End Cover
SET	77	1	0244-90068-02	Self Tapping Screw (Set of 2)

UPPER FRAME ASSEMBLY

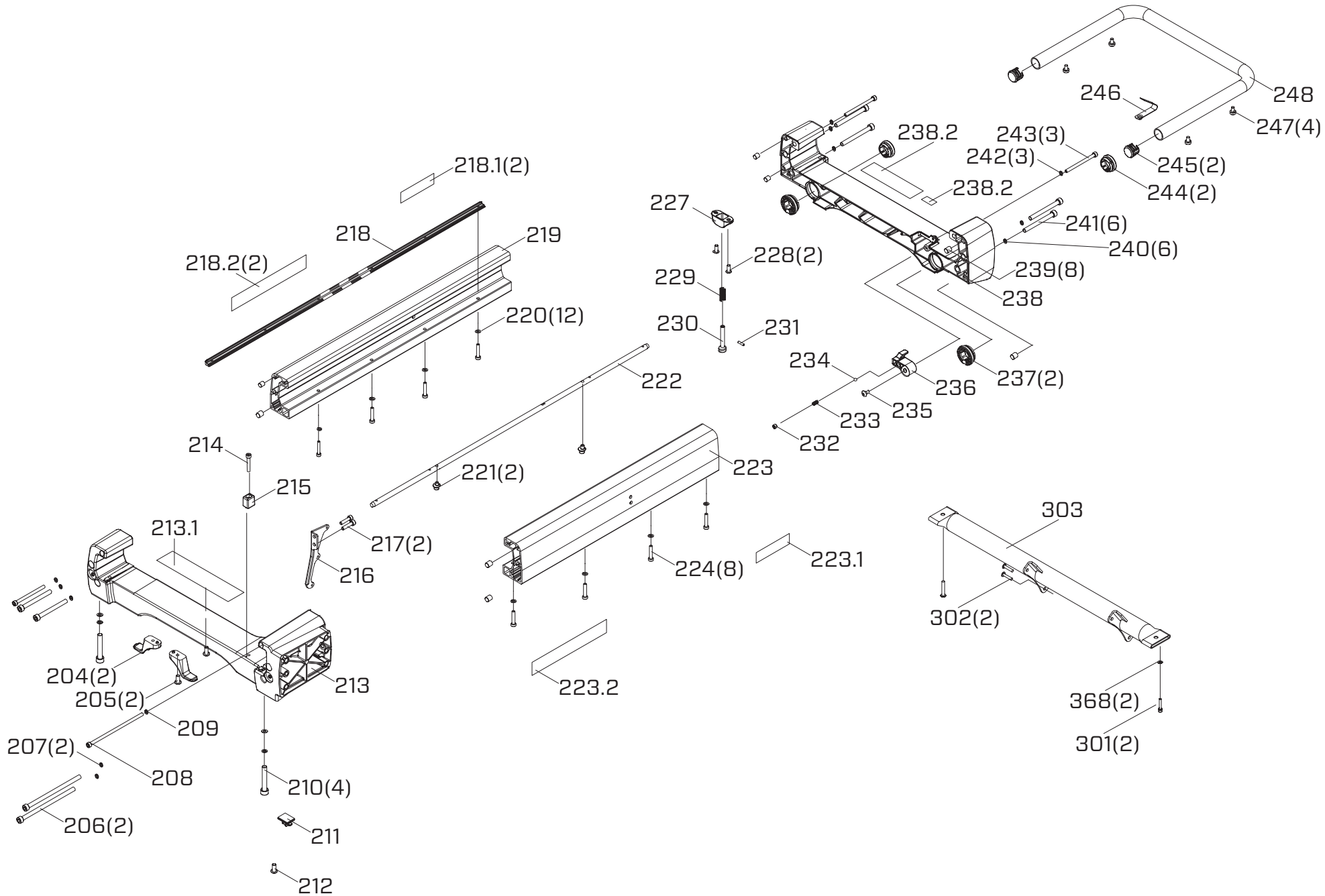

UPPER FRAME ASSEMBLY

ASSEMBLY KIT / SET	ITEM NO	QTY	PART NO	DESCRIPTION
K17	K17	1	0362-90017-01	Cord Storage Hooks
	204	2		Cord Storage
	205	2		Screw
K18	K18	1	0362-90018-01	Screws, Washers
	206	2		Hex Screw
	207	2		Lock Washer
K19	K19	1	0362-90019-01	Screws, Washers
	208	1		Hex Screw
	209	1		Lock Washer
	211	1	0244-00128-01	Cord Clamp
	212	1	0244-00127-01	Screw
	213	1	0244-00130-01	Cross Support Back
K20	K20	1	0362-90020-01	Screws, Plugs
	214	1		Socket Head Screw
	215	1		Stopper
	216	1	0244-00133-01	Vacuum Locking Bracket
SET	217	1	0244-90090-01	Hex Screw w/ Washer (Set of 2)
	218	1	0244-00135-01	Rolling Table Support Bar
	219	1	0244-00136-01	Support Rail Right
K21	K21	1	0362-90021-01	Hardware Kit
	220	12		Washer
	224	8		Hex Screw
	210	4		Hex Screw w/Washer
SET	221	1	0244-90091-01	Cam (Set of 2)
	222	1	0244-00139-01	Rolling Table Guide Bar
	223	1	0244-00143-01	Support Rail Left

ASSEMBLY KIT / SET	ITEM NO	QTY	PART NO	DESCRIPTION
K22	K22	1	0362-90022-01	Handle Lock Pin Kit
	227	1		Cover
	228	2		Screw
	229	1		Spring
	230	1		Locking Pin
	231	1		Pin
K53	K53	1	0362-90051-01	Table Stop Lever Kit
	232	1		Set Screw
	233	1		Spring
	234	1		Detent Ball
	235	1		Shoulder Screw
	236	1		Table Stop Lever
K23	K23	1	0362-90023-01	Spindle Hardware Kit
	237	2		Tube Bushing
	244	2		Tube Bushing
	238	1	0244-00155-01	Cross Support Front
SET	239	1	0244-90092-01	Location Pin (Set of 8)
K24	K24	1	0362-90024-01	Screws, Washers
	240	6		Lock Washer
	241	6		Hex Soc Screw
K25	K25	1	0362-90025-01	Screws, Washers
	242	3		Lock Washer
	243	3		Hex Soc Screw
K26	K26	1	0362-90026-01	Handle Hardware Kit
	245	2		Tube Cap
	246	2		Spring Lock Pin
	247	4		Screw
	248	1	0244-00163-01	Transport Handle
	303	1	0244-00362-01	Vac Housing Cross Support
K36	K36	1	0362-90050-01	Cross Support Hardware Kit
	301	2		Screw
	302	2		Screw
	368	2		Flat Washer

ROLLING TABLE

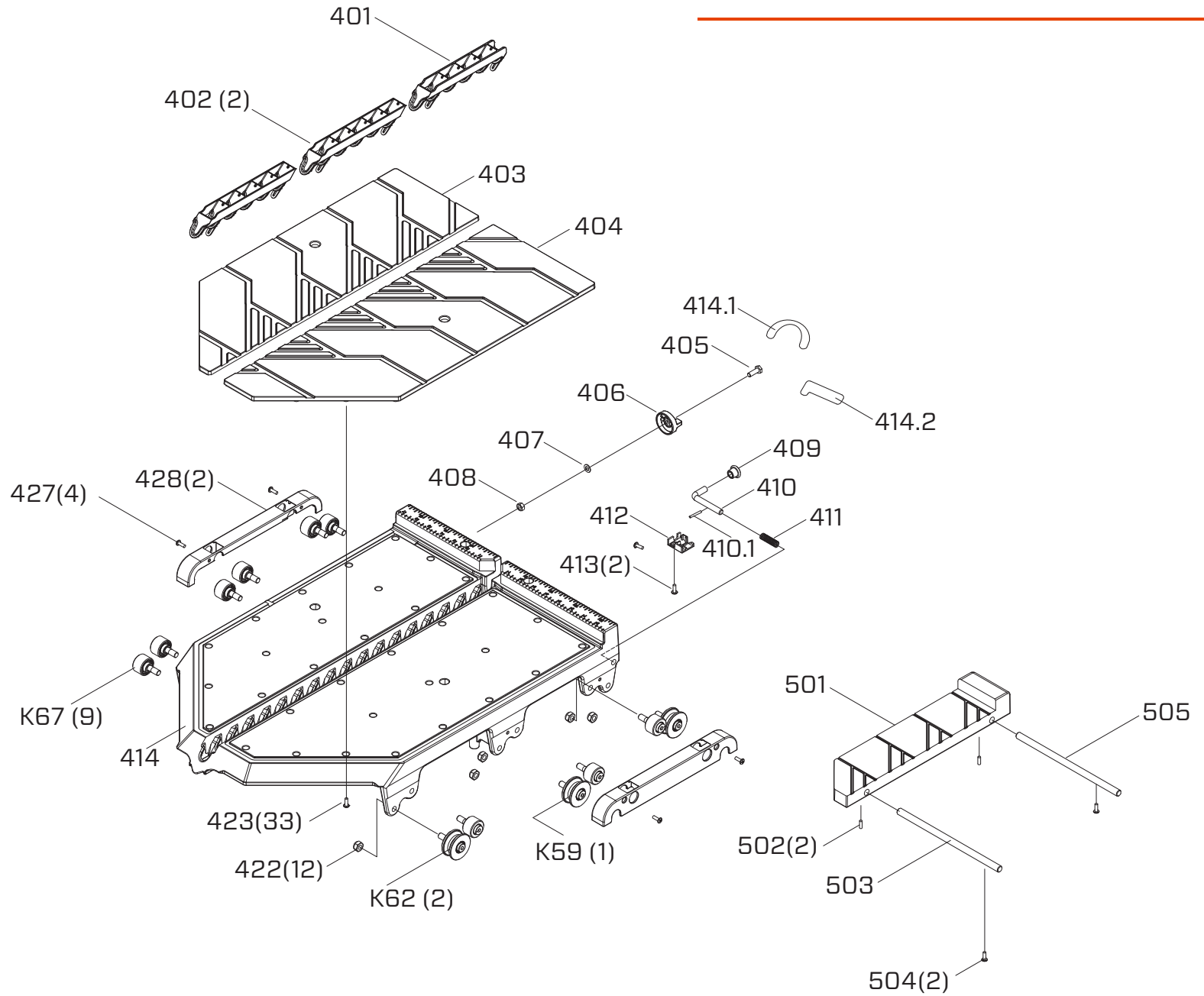

ROLLING TABLE

ASSEMBLY KIT/ SET	ITEM NO	QTY	PART NO	DESCRIPTION
A8	A8	1	iQ2X-RT	iQ244/362 Series - Rolling Table
K56	K56	1	0244-90001-00	Table Louver Kit
	401	1		Front Table Louver
	402	2		Rear Table Louver
	403	1	0244-00402-01	Table Pad , Right
	404	1	0244-00403-01	Table Pad , Left
K57	K57	1	0244-90021-01	Extension Table Lock Kit
	405	1		Hex Screw
	406	1		Extension Table Lock
	407	1		Flat Washer
	408	1		Lock Nut
K58	K58	1	0244-90020-01	Table Knob Lock Kit
	409	1		Knob
	410	1		Table Lock Pin
	410.1	1		Spring Pin
	411	1		Compression Spring
	412	1		Table Lock Pin Holder
	413	2		Flange Screw
	414	1	0244-00413-01	Roller Table
K59	K59	1	0244-90010-02	Adjustable Guide Wheel
K60	K60	1	0244-90018-01	Spacer Kit
	416	10		Spacer
K61	K61	1	0244-90015-01	Guide Wheel Screw Kit
	417	2		Guide Wheel
K62	K62	2	0244-90011-02	Non-Adjustable Guide Wheel

ASSEMBLY KIT/ SET	ITEM NO	QTY	PART NO	DESCRIPTION	
K63	K63	1	0244-90014-01	Small Spacer Kit	
	420	2		Small Spacer	
K64	K64	1	0244-90013-01	Internal Retaining Ring Kit	
	421	12		Internal Retaining Ring	
K65	K65	1	0244-90017-01	Lock Nut Kit	
	422	12			
K66	K66	1	0244-90016-01	Tap Screw Kit	
	423	33			
K67	K67	9	0244-90009-02	Adjustable Support Wheel	
		426	10	0244-00425-01	Adjustable Cam Screw
K68	K68	1	0244-90012-01	Wheel Cover Kit	
	427	4		Screw	
	428	2		Wheel Cover	
K72	K72	1	0362-90067-01	Rolling Table Extension Wing Kit	
		501		1	Extension Wing
		503		1	Extension Rod
		505		1	Extension Rod w/Flat Side
K14	K14	1	0244-90022-01	Screw Kit	
	502	2		Set Screw	
	504	2		Screw	

MITER GAUGE

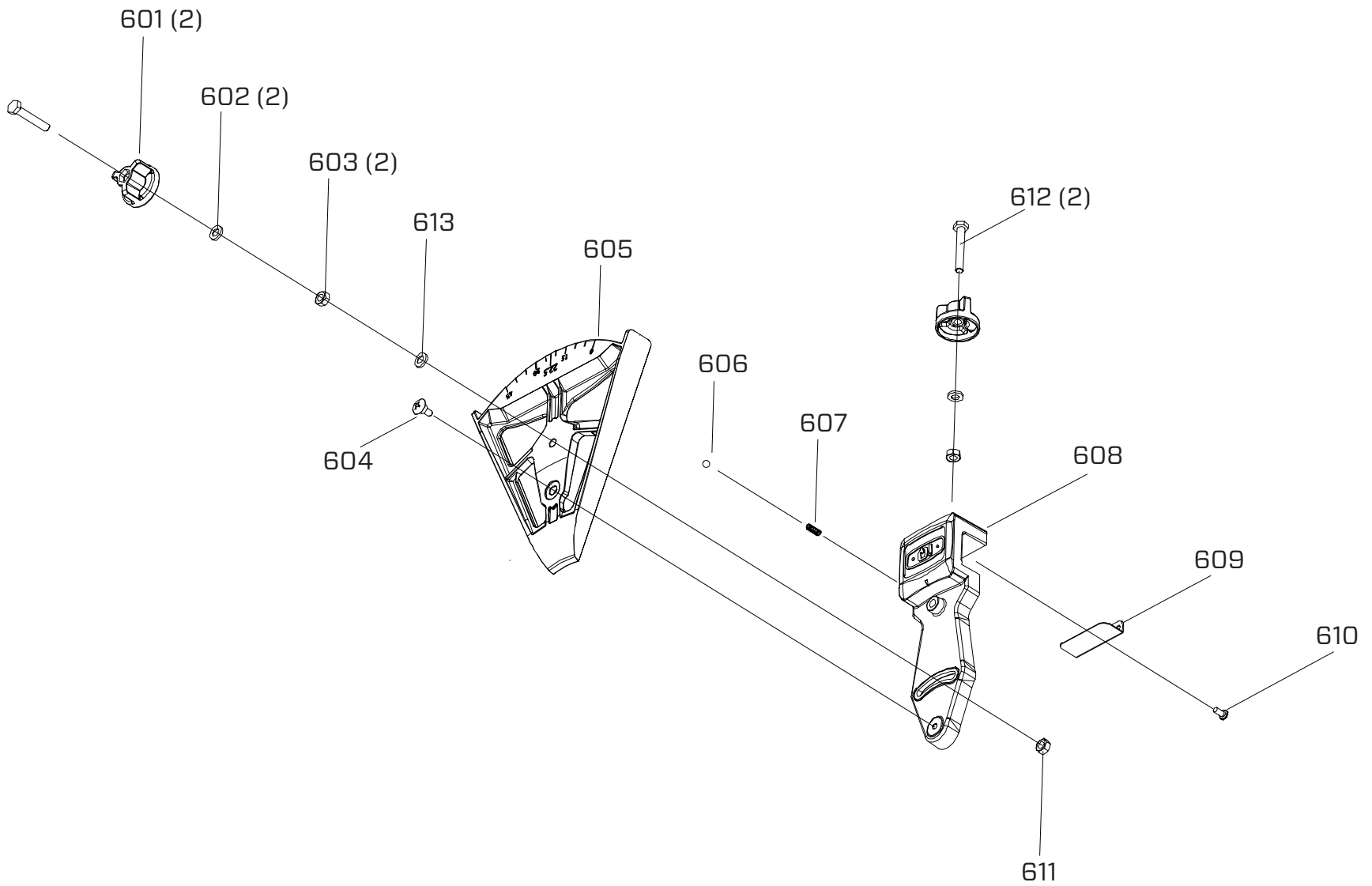

MITER GAUGE

ASSEMBLY KIT/ SET	ITEM NO	QTY	PART NO	DESCRIPTION
K70	K70	1	0244-90002-01	Miter Gauge Kit
	601	2		Knob
	602	2		Flat Washer
	603	2		Lock Nut
	604	1		Screw
	605	1		Miter Gauge
	606	1		Steel Ball
	607	1		Spring
	608	1		Miter Gauge Saddle
	609	1		Fence Liner
	610	1		Flange Screw
	611	1		Hex Nut
	612	2		Hex HD Screw
	613	1		Flat Washer

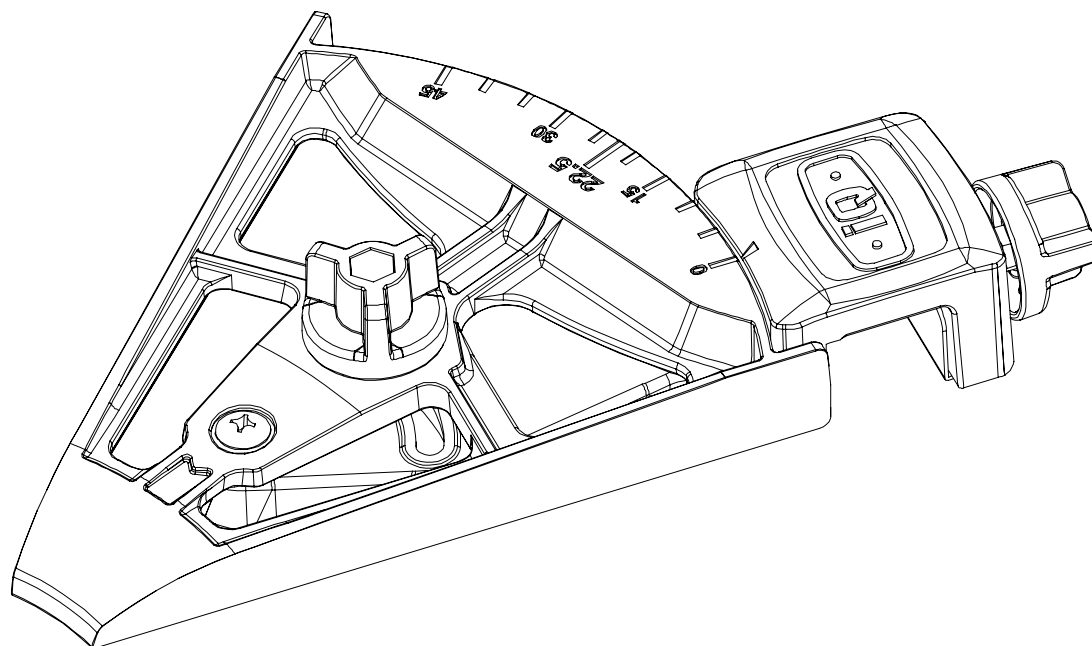

VACUUM SYSTEM

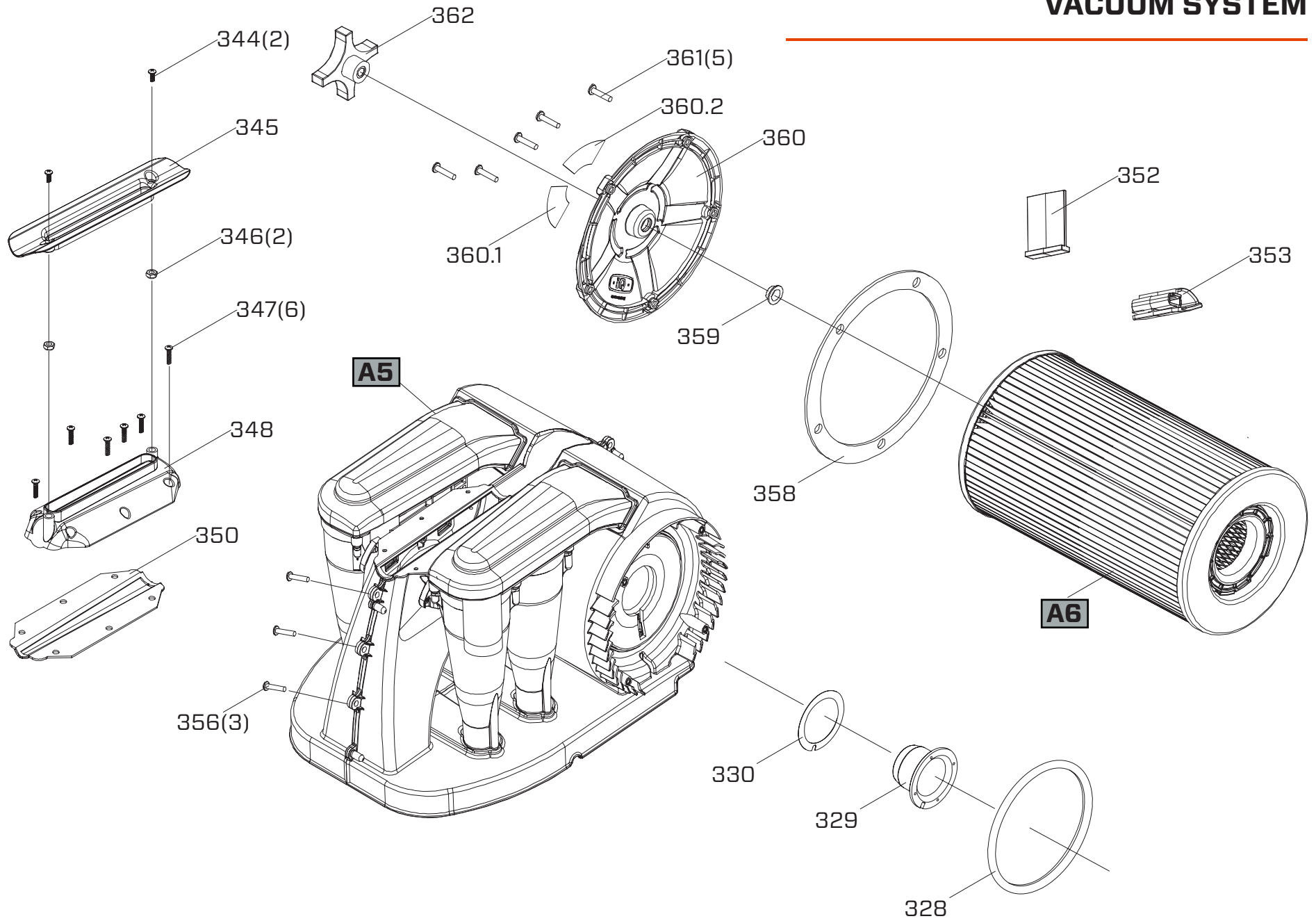

VACUUM SYSTEM

ASSEMBLY KIT/ SET	ITEM NO	QTY	PART NO	DESCRIPTION
A5	A5	1	0362-25004-01	Vacuum Housing Assembly
K32	K32	1	0362-90031-01	Hardware Kit
	344	2		Hex Screw
	346	2		Lock Nut
	345	1	0362-00345-01	Top Vacuum Slot
SET	347	1	0244-90102-01	Self Taping Screw (Set of 6)
	348	1	0362-00348-01	Top Vacuum Slot Mount
	350	1	0244-00338-01	Gasket
SET	356	1	0244-90072-01	Screw (Set of 3)
	358	1	0244-00352-01	Gasket
K33	K33	1	0362-90032-01	Filter Cover Kit
	359	1		Bushing
	360	1		Filter Cover
SET	361	1	0244-90099-01	Socket Hex Screw (Set of 5)
	362	1	0244-00355-01	Knob
A6	A6	1	0244-25001-01	Replacement Filter Assembly
K29	K29	1	0362-90029-01	Filter Cleaning Tab & Mount
	352	1		Filter Cleaning Tab
	353	1		Filter Cleaning Tab Mount
K28	K28	1	0362-90028-01	Spindle and Gasket Kit
	328	1		Gasket
	329	1		Filter Spindle
	330	1		Gasket

VACUUM MOTOR

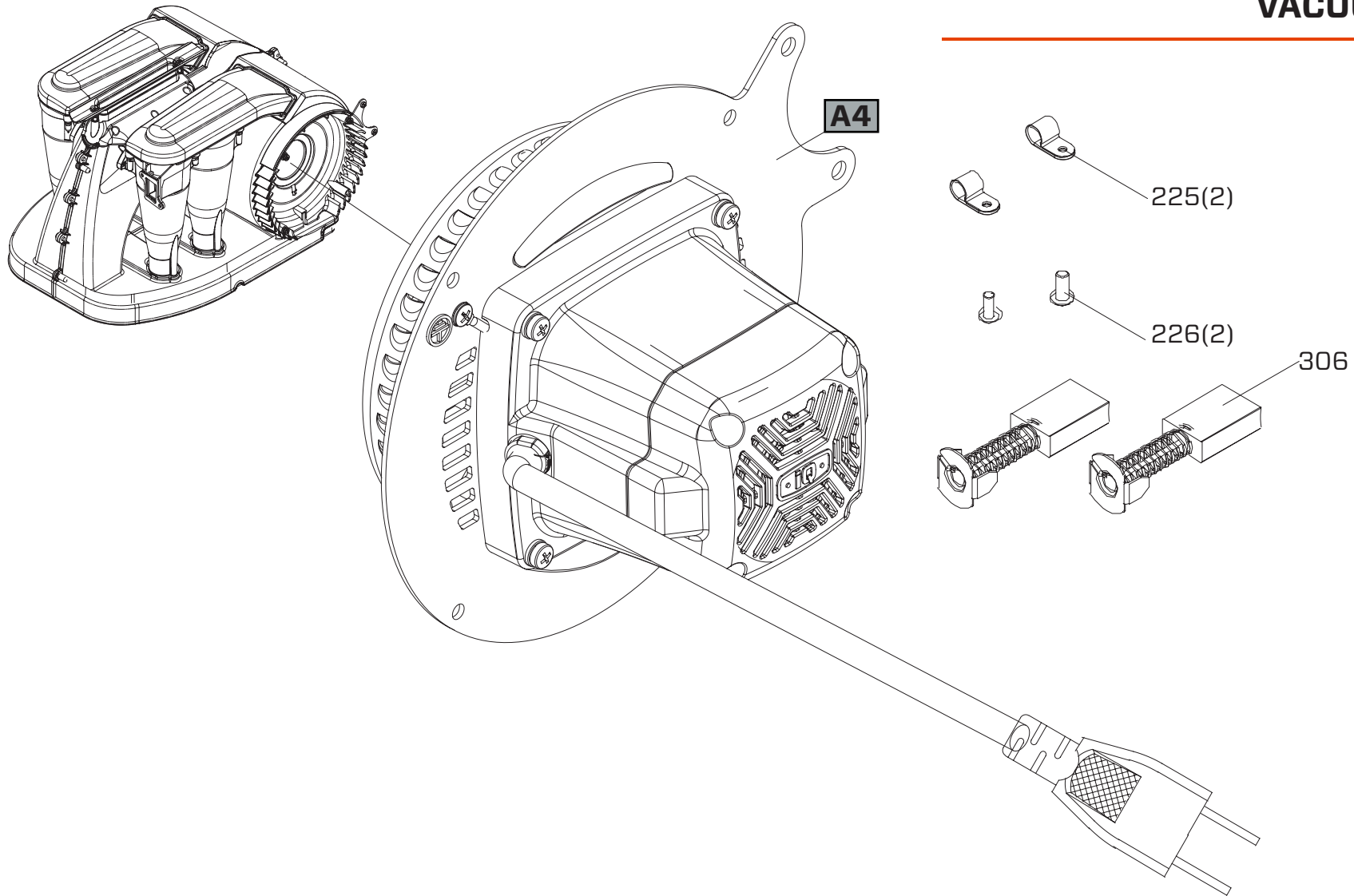

ASSEMBLY KIT/ SET	ITEM NO	QTY	PART NO	DESCRIPTION
A4	A4	1	0244-25004-03	Vacuum Motor 120v
SET	306	1	0244-90097-01	Vacuum Motor Brushes (Set of 2)
SET	K73	1	0244-90104-01	Cable Clamp/Screw (Set of 2)
	225	2		Cable Clamp
	226	2		Flange Screw

DUST CONTAINMENT TUB

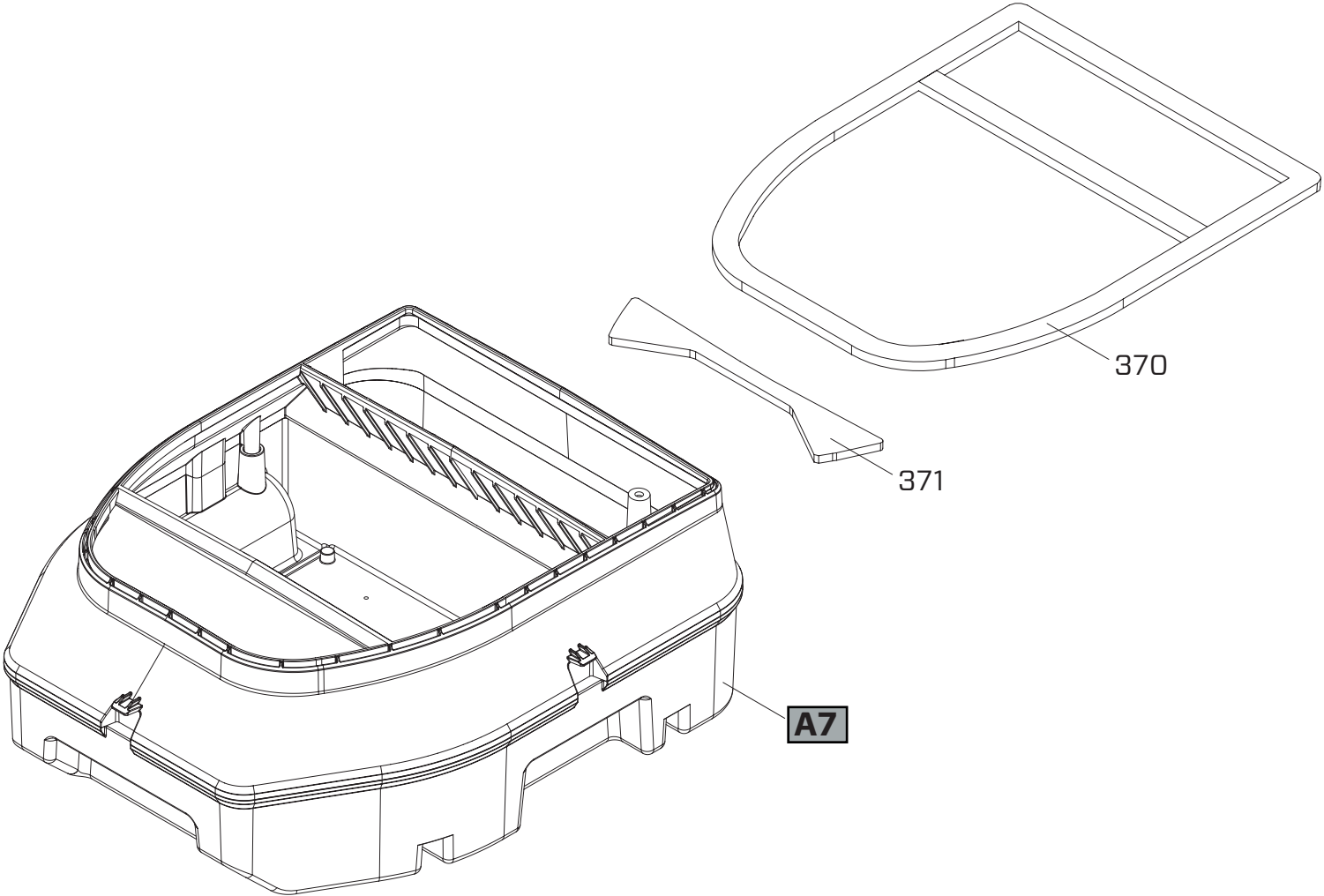

ASSEMBLY KIT/ SET	ITEM NO	QTY	PART NO	DESCRIPTION
K34	K34	1	0362-90033-01	Dust Tray Gasket Kit
	370	1		Tray Gasket
	371	1		Tray Gasket
A7	A7	1	0362-25003-01	Dust Tray Assembly

LOWER FRAME ASSEMBLY

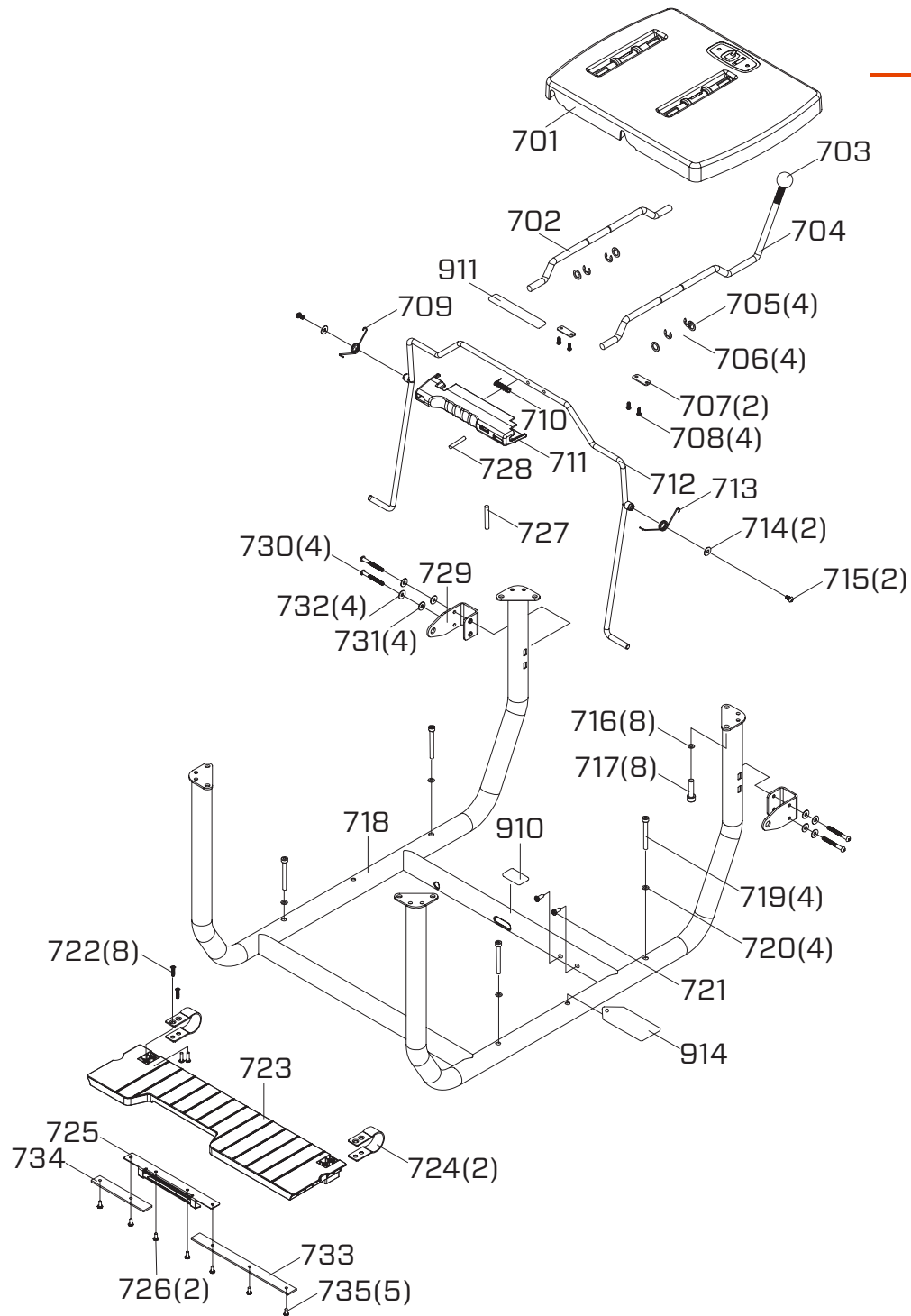

LOWER FRAME ASSEMBLY

ASSEMBLY KIT/ SET	ITEM NO	QTY	PART NO	DESCRIPTION
	701	1	0362-00701-01	Tray Support Plate
	702	1	0362-00702-01	Tray Link Rod, Short
	703	1	0362-00703-01	Tray Link Rod Handle
	704	1	0362-00704-01	Tray Link Rod, Long
K37	K37	1	0362-90035-01	Hardware Kit
	705	4		Flat Washer
	706	4		E-Clip
	707	2		Plate
	708	4		Screw
K38	K38	1	0362-90036-01	Latch Linkage Rod Kit
	712	1		Latch Linkage Rod
	728	1		Pin
K39	K39	1	0362-90037-01	Hardware Kit
	709	1		Spring, Left
	713	1		Spring, Right
	714	2		Washer
	715	2		Screw
K40	K40	1	0362-90038-01	Handle and Hardware Kit
	710	1		Spring
	711	1		Handle
	727	2		Roll Pin

ASSEMBLY KIT/ SET	ITEM NO	QTY	PART NO	DESCRIPTION
K41	K41	1	0362-90039-01	Hardware Kit
	730	4		Screw
	731	4		Washer
	732	4		Washer
SET	729	1	0362-90080-01	Bracket (Set of 2)
K42	K42	1	0362-90040-01	Hardware Kit
	716	8		Washer
	717	8		Hex Screw
	718	1	0362-00718-01	Frame
K43	K43	1	0362-90041-01	Hardware Kit
	719	4		Hex screw
	720	4		Washer
	721	2		Screw
	723	1	0362-00723-01	Hinge Plate
K44	K44	1	0362-90042-01	Hinge Strap and Hardware
	722	8		Screw
	724	2		Hinge Strap
K45	K45	1	0362-90043-01	Brackets and Hardware
	733	1		Reinforcing Plate, Long
	734	1		Reinforcing Plate, Short
	735	5		Screw
K46	K46	1	0362-90044-01	Lift Slot Bracket and Hardware
	725	1		Reinforcing Bracket
	726	2		Screw

STAND ASSEMBLY

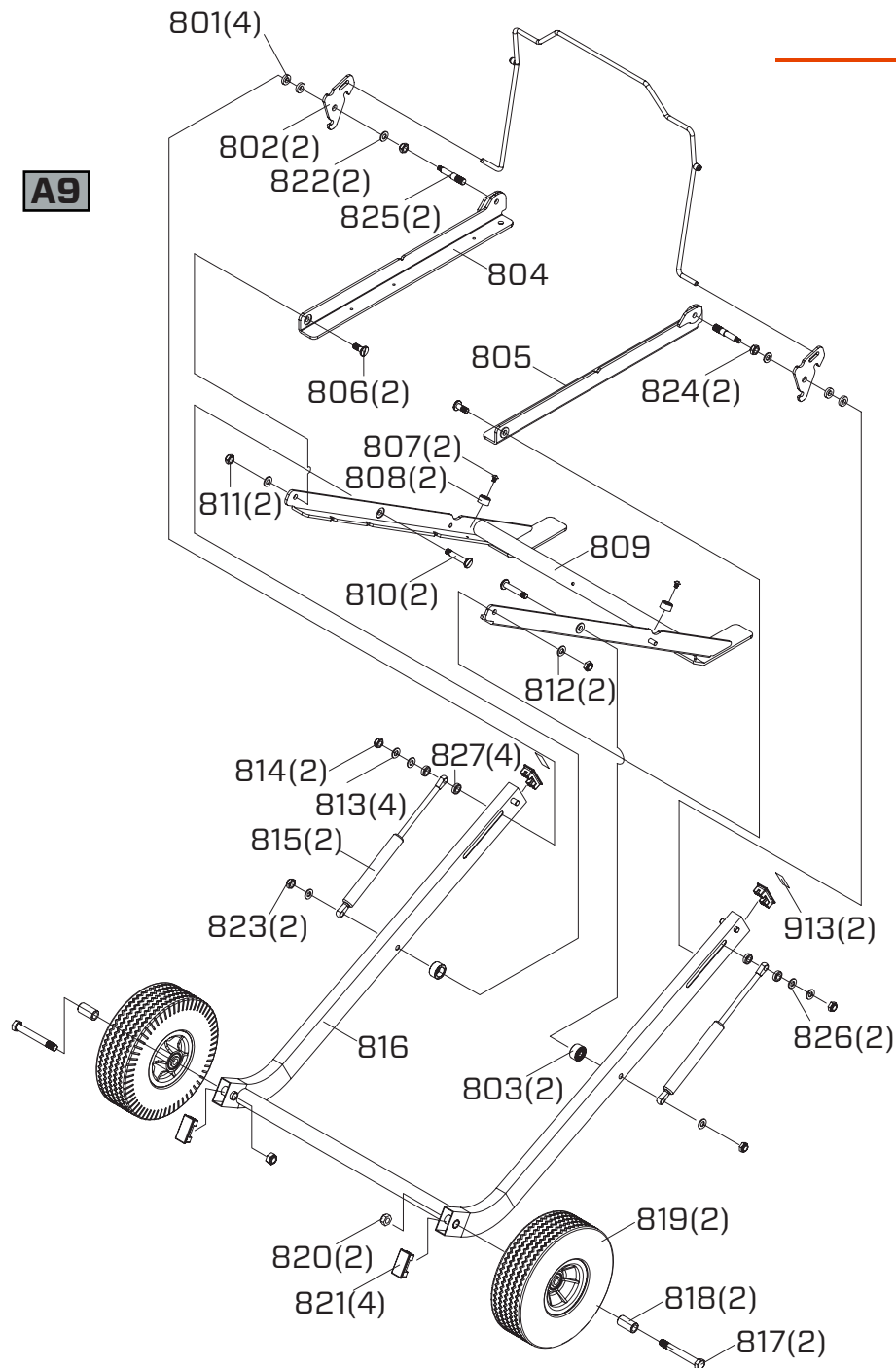

STAND ASSEMBLY

ASSEMBLY KIT/ SET	ITEM NO	QTY	PART NO	DESCRIPTION
A9	A9	1	0362-90107-01	iQMS362 Stand Assembly
K47	K47	1	0362-90045-01	Hardware Kit
	801	4		Washer
	822	2		Washer
	824	2		Hex Nut
SET	802	1	0362-90081-01	Latch Plate (set of 2)
SET	803	1	0362-90082-01	Spacer Ring (Set of 2)
	804	1	0362-00804-01	Stand, Left
	805	1	0362-00805-01	Stand, Right
K49	K49	1	0362-90047-01	Hardware Kit
	806	2		Screw
	811	2		Lock Nut
	812	2		Washer
K48	K48	1	0362-90046-01	Foot
	807	2		Shoulder Screw
	808	2		Foot Pad
	809	1	0362-00809-01	Stand, Front
SET	810	1	0362-90083-01	Screw (Set of 2)
K50	K50	1	0362-90048-01	Bushing and Hardware
	813	4		Washer
	814	2		Lock Nut
	826	2		Plastic Washer
	815	2	0362-00815-01	Gas Spring
	816	1	0362-00816-01	Stand, Rear
K51	K51	1	0362-90055-01	Wheel Kit
	818	2		Bushing
	819	2		Wheel
K52	K52	1	0362-90049-01	Wheel Axel Hardware Kit
	817	2		Hex Screw
	820	2		Wheel Hardware
SET	821	1	0362-90084-01	Stand End Cover (Set of 4)
SET	823	1	0362-90085-01	Lock Nut (Set of 2)
SET	825	1	0362-90086-01	Shoulder Screw (Set of 2)
SET	827	1	0362-90087-01	Bushing (Set of 4)

WARRANTY

New iQMS362™ Dry Cut Masonry Saw, sold by iQ Power Tools or an iQ authorized dealer is warranted to be free from manufacturing defects in normal service for a one year period from date of purchase by the original consumer purchaser. Warranty period for rental items is 90 days.

All iQ products must be registered either through our website or by mailing in the Warranty Card in order for the warranty to be active and valid. This Warranty shall not apply to any parts that have been subjected to misuse or improper service, damaged in transit or handling, altered or repaired by unauthorized representatives, or used with a blade that is not recommended by iQ Power Tools.

Any claim arising under this Warranty must be submitted by the original purchaser within the Warranty period specified above and must include proof of purchase. Within Warranty period, options are either to replace or repair any parts or components that are found to be defective by iQ Power Tools at no charge to the original purchaser. iQ Power Tools shall not be responsible or obligated to pay for freight or other transportation-related costs or expenses in connection with any defective products, replacements, or components that are returned to iQ Power Tools facility or any authorized repair station.

Parts and labor needed to maintain products, and the replacement of components due to normal wear and tear, are the purchaser's responsibility and are not covered by this Warranty. All products or components replaced under Warranty become the property of the manufacturer. All replacement parts will be considered to be part of the original product and any Warranty on such parts will expire concurrently with this original Warranty.

iQ Power Tools will pay for parts and labor in connection with Warranty repairs conducted by iQ Power Tools or its authorized repair center. Replacement parts installed by anyone else will be provided without a charge but this Warranty will not apply to labor charges in connection therewith.

IN NO EVENT SHALL ANY LIABILITY UNDER THIS WARRANTY EXCEED THE REPLACEMENT COST OF ANY DEFECTIVE PRODUCT OR COMPONENT THEREOF. iQ POWER TOOLS SHALL NOT BE LIABLE FOR ANY INCIDENTAL OR CONSEQUENTIAL DAMAGES OR FOR ANY OTHER DAMAGE OR LOSS NOT EXPRESSLY ASSUMED AS SET FORTH HEREIN.

The Warranty on the terms above is the only Warranty. This limited Warranty is expressly in lieu of all other Warranties, whether expressed or implied.